

ORIENT



INDIA DISTRIBUTOR OF ORIENT ELECTRONICS KOREA

PROXIMWORLD GLOBAL CORP.

contact:+919873101071

E-Mail: sales@proximworld.org.

<https://www.proximworld.org>



Orient Electronics

Innovation and Reliability





- Compact Size
- Wide Input Voltage Range (Universal input)
- Installation on DIN Rail (35mm only)
- Built in PFC (180W, 240W, 480W, 960W)
- Over Voltage Protection
- Over Current Protection
- LED Indicator for DC Power ON (green)
- LED Indicator for DC Low (red)
- 3 Year Warranty

FDR 15-24

① ② ③

① Series name ② Total output wattage ③ Output voltage

NEW!

NEW!

MODEL	FDR15	FDR30	FDR50	FDR70	FDR120	FDR180	FDR240	FDR480	FDR960
INPUT VOLTAGE, FREQUENCY	AC100-240V(AC90~264 or DC127~370V), 50/60Hz Universal Input								
OUTPUT VOLTAGE/ CURRENT	5V	2A	-	-	-	-	-	-	-
	12V	1.2A	2.5A	-	-	-	-	-	-
	24V	0.65A	1.3A	2.2A	3A	5A	7.5A	10A	20A
	48V	-	-	1.1A	1.5A	2.5A	3.8A	5A	10A
INPUT CURRENT [A] (Io=100%)	110V	0.45	0.9	1.0	1.5	2.4	2.0	2.5	5.0
	220V	0.3	0.6	0.6	1.0	1.4	1.0	1.25	2.5
EFFICIENCY [%]	110V	82 typ	84 typ	86 typ	86 typ	85 typ	88 typ	89 typ	90 typ
	220V	79 typ	84 typ	86 typ	88 typ	87 typ	90 typ	91 typ	90 typ
POWER FACTOR	110V	-	-	-	-	-	0.98 typ	0.98 typ	0.98 typ
	220V	-	-	-	-	-	0.93 typ	0.93 typ	0.93 typ
OPERATING TEMP AND HUMID	-25~+70°C (Required Derating), 20~90% RH (Non Condensing)								
SAFETY REGULATION	UL, C-UL, CE, CB								
SIZE(W×H×D/mm)	22.5×95×108	36×95×108	30×130×125	33×130×125	40×130×125	50×130×125	60×130×125	86.5×130×128	110×125×150
WEIGHT(g)	200	250	570	650	800	1000	1200	1700	2000

*1 Input voltage of FDR960 is "AC200-240V(AC185~264 or DC260~370V), 50/60Hz"

* Efficiency is based on a 24V reference.

* More detail specification, visit ORIENT Electronics website and find FDR series

FDR 15
FDR 30
FDR 50
FDR 70
FDR 120
Series

Block Diagram

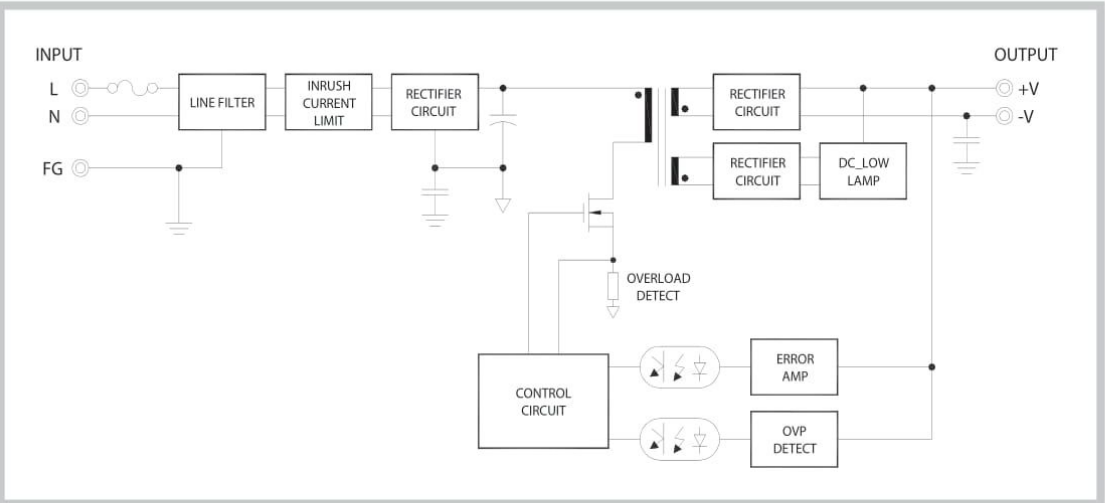

FDR 180
FDR 240
FDR 480
Series

Block Diagram

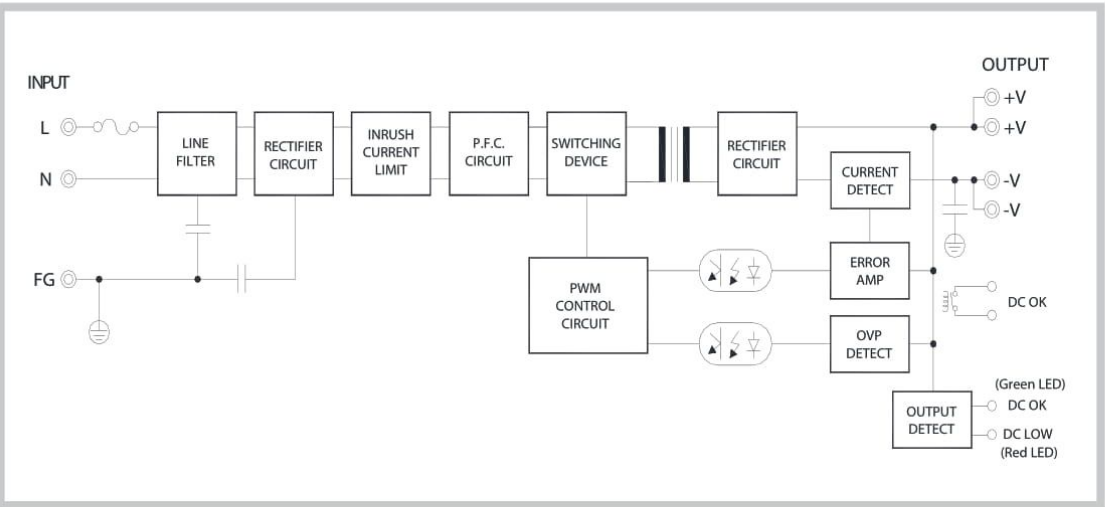

Output Derating Curve

FDR15, 30

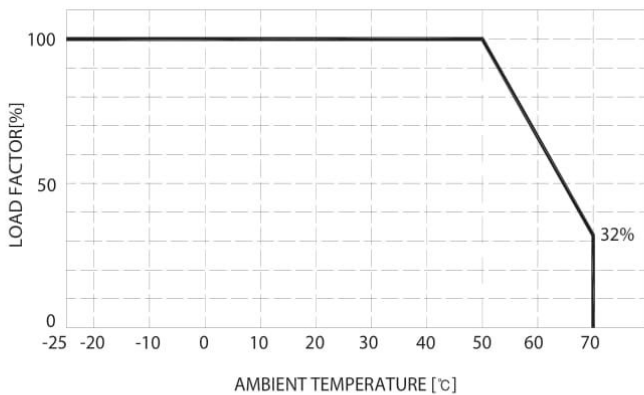

FDR50, 70, 120, 180, 240, 480

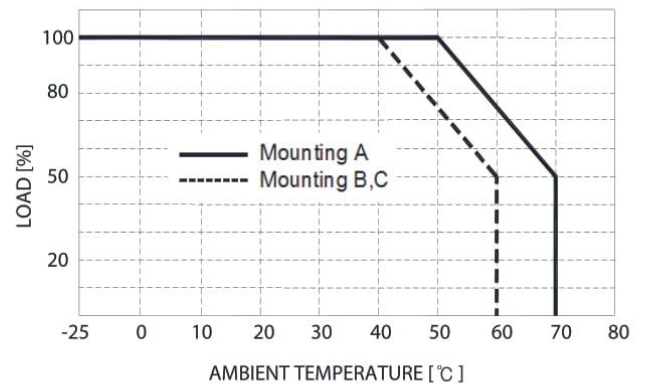

주) 주위 온도를 -25°C~0°C 조건에서 제품을 사용할 경우 출력 Ripple&Noise가 기준을 초과할 수 있으므로 고려하여 사용하시기 바랍니다.

Design Drawing

FDR15-Series

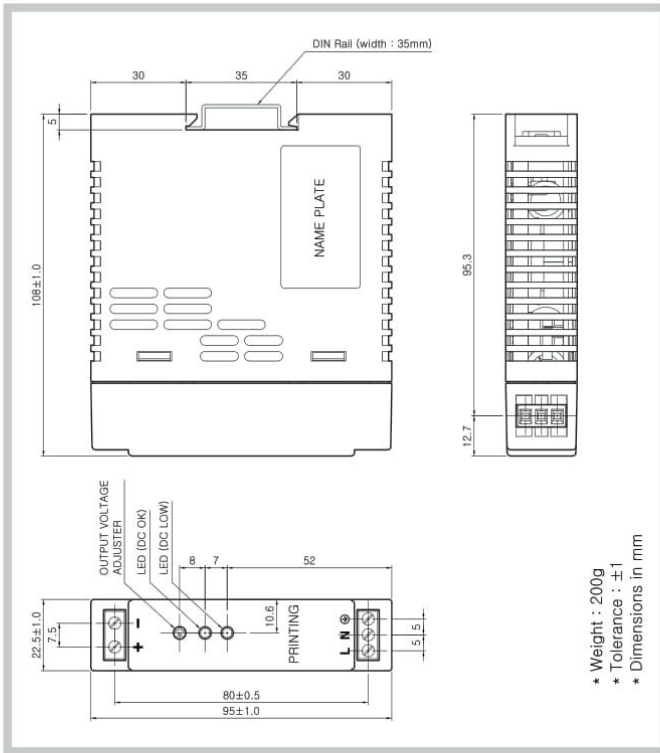

FDR30-Series

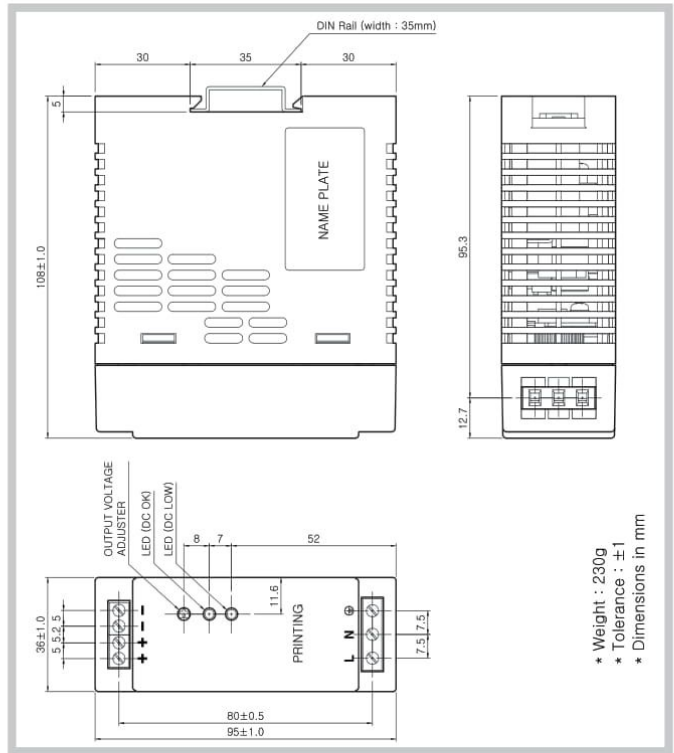

Design Drawing

FDR50-Series

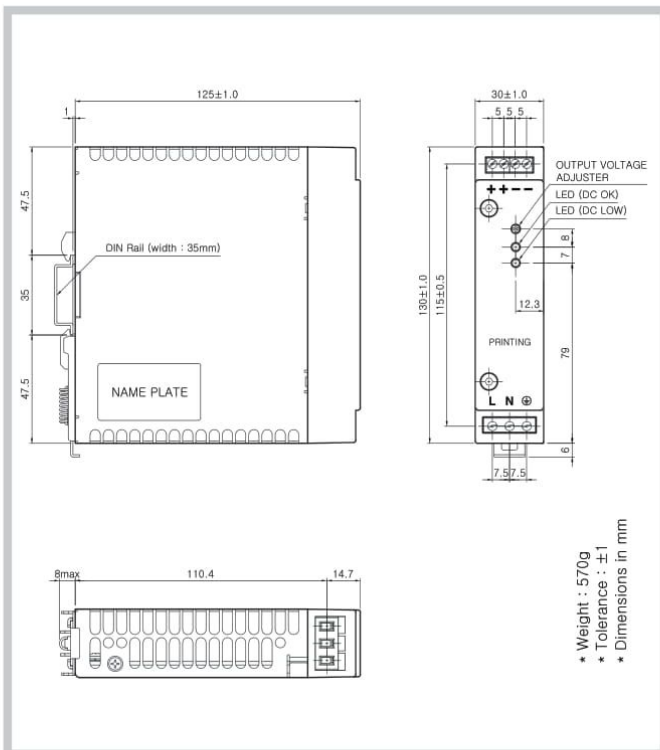

FDR70-Series

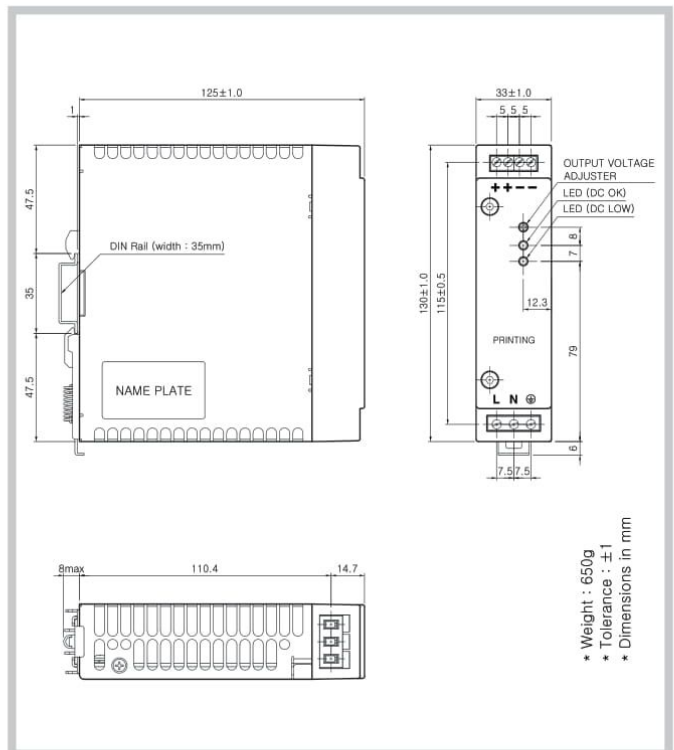

Design Drawing

FDR120-Series

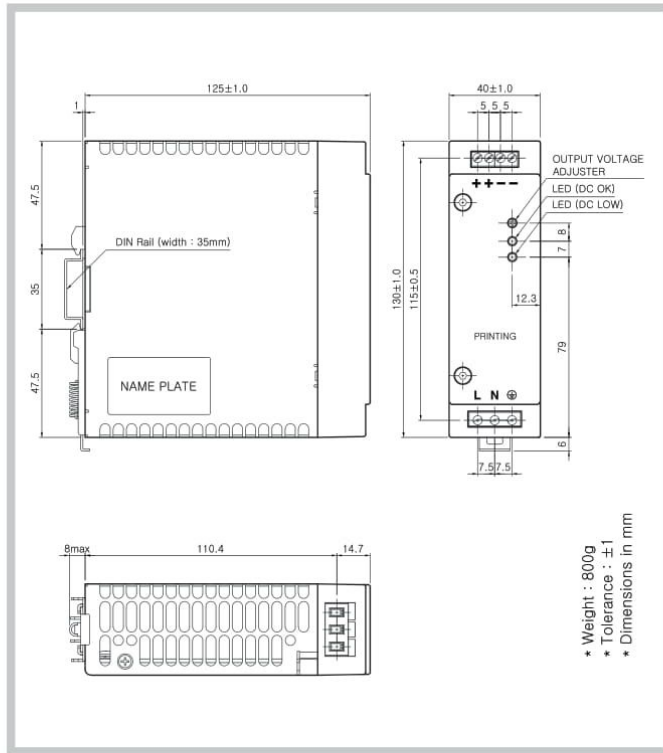

FDR180-Series

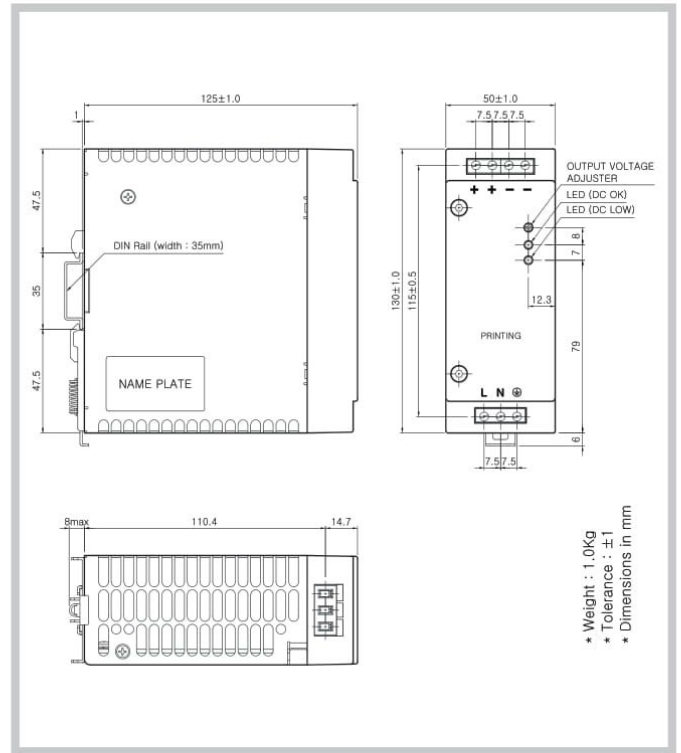

Design Drawing

FDR240-Series

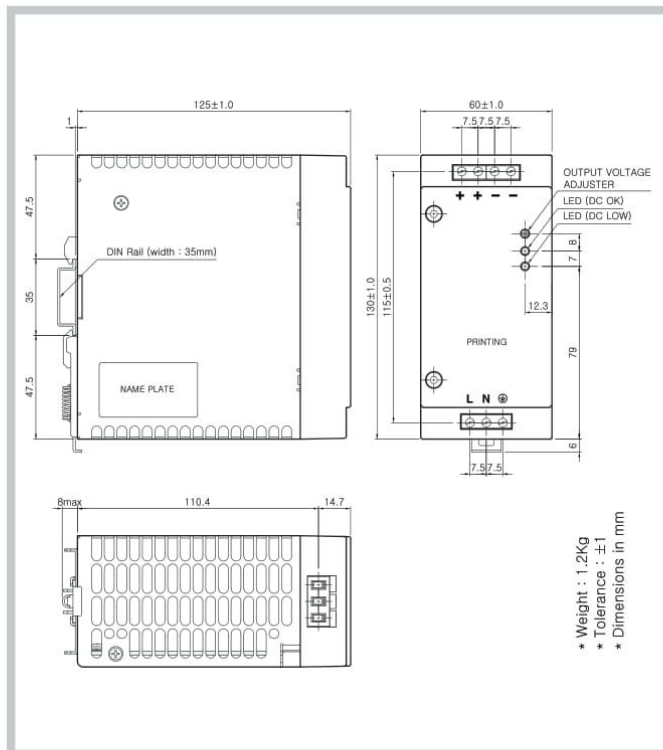

FDR480-Series

